



## SSCE3V372N1

### 1-Line Bi-directional TVS Diodes

#### ● Description

The SSCE3V372N1 is a bi-directional TVS diode, utilizing leading monolithic silicon technology to provide fast response time and low ESD clamping voltage, making this device an ideal solution for protecting voltage sensitive data and power line. The SSCE3V372N1 complies with the IEC 61000-4-2 (ESD) with  $\pm 30$  kV air and  $\pm 30$  kV contact discharge. It is assembled into an ultra-small 1.0x0.6x0.5mm lead-free DFN package. The small size and high ESD surge protection make SSCE3V372N1 an ideal choice to protect cell phone, digital cameras, audio players and many other portable applications.

#### ● Feature

- ✧ Working voltage: 3.3V
- ✧ Low clamping voltage
- ✧ Small Body Outline Dimensions
- ✧ Low leakage current
- ✧ Response Time is Typically <1ns
- ✧ Complies with following standards:
  - IEC 61000-4-2 (ESD) immunity test
    - Air discharge:  $\pm 30$ kV
    - Contact discharge:  $\pm 30$ kV
  - IEC61000-4-5 (Lightning) 18A (8/20 $\mu$ s)

#### ● Mechanical data

- ✧ Package: DFN1006-2L(1.0x0.6x0.5mm)
- ✧ Lead finish: 100% matte Sn (Tin)
- ✧ Device meets MSL 3 requirements
- ✧ Case Material: "Green" Molding Compound
- ✧ RoHS Compliant

#### ● PIN configuration

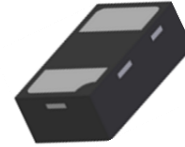

**DFN1006-2L (Bottom View)**

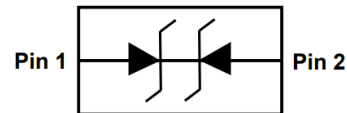

**Circuit Diagram**

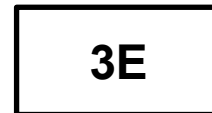

**Marking**

#### ● Applications

- ✧ Cellular Handsets and Accessories
- ✧ Personal Digital Assistants
- ✧ Notebooks and Handhelds
- ✧ Portable Instrumentation
- ✧ Digital Cameras
- ✧ Peripherals
- ✧ Audio Players
- ✧ Keypads, Side Keys, USB, LCD Displays



## ● Electronic Parameter

Symbol	Parameter
$V_{RWM}$	Peak Reverse Working Voltage
$I_R$	Reverse Leakage Current @ $V_{RWM}$
$V_{BR}$	Breakdown Voltage @ $I_T$
$I_T$	Test Current
$I_{PP}$	Maximum Reverse Peak Pulse Current
$V_C$	Clamping Voltage @ $I_{PP}$
$P_{PP}$	Peak Pulse Power
$C$	Junction Capacitance

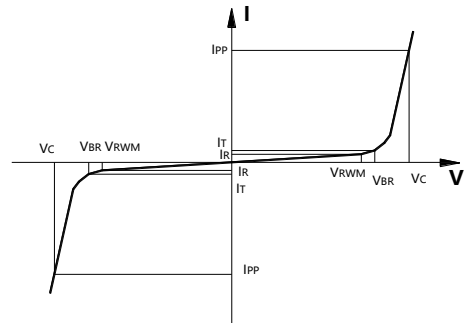

## ● Absolute maximum rating @ $T_A=25^{\circ}C$

Parameter	Symbol	Value	Unit
Peak Pulse Power (8/20 $\mu$ s)	$P_{PP}$	234	W
Peak Pulse Current (8/20 $\mu$ s)	$I_{PP}$	18	A
ESD Rating per IEC61000-4-2:	Contact	$\pm 30$	kV
		Air	
Storage Temperature	$T_{STG}$	-55/+150	$^{\circ}C$
Operating Temperature	$T_J$	-55/+125	$^{\circ}C$

## ● Electrical Characteristics @ $T_A=25^{\circ}C$

Parameter	Symbol	Conditions	Min.	Typ.	Max.	Unit
Peak Reverse Working Voltage	$V_{RWM}$				3.3	V
Breakdown Voltage	$V_{BR}$	$I_T = 1mA$	3.8		6.2	V
Reverse Leakage Current	$I_R$	$V_{RWM} = 3.3V$			0.1	$\mu A$
Clamping Voltage	$V_C$	$I_{PP} = 1A, t_P = 8/20\mu s$		6.5		V
Clamping Voltage	$V_C$	$I_{PP} = 18A, t_P = 8/20\mu s$		8.5	13	V
Junction Capacitance	$C_J$	$V_R = 0V, f = 1MHz$		35		pF



## ● Typical Performance Characteristics

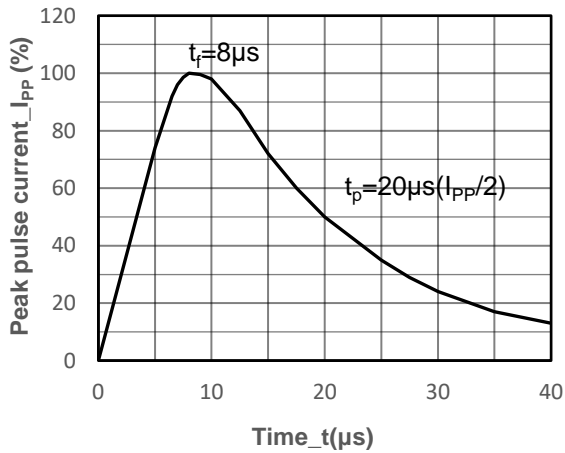

8/20µs Pulse Waveform

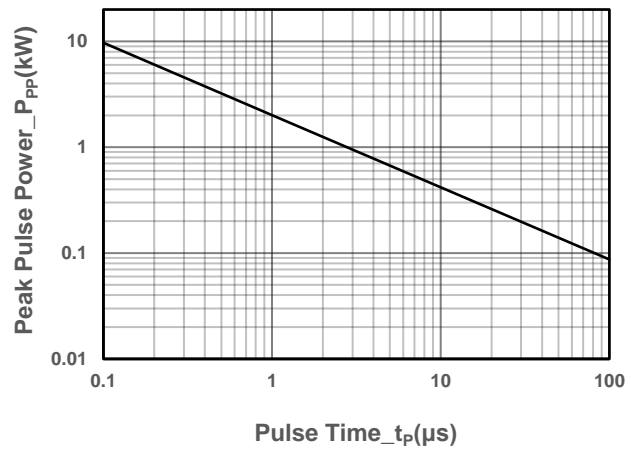

Peak Pulse Power vs. Pulse Time

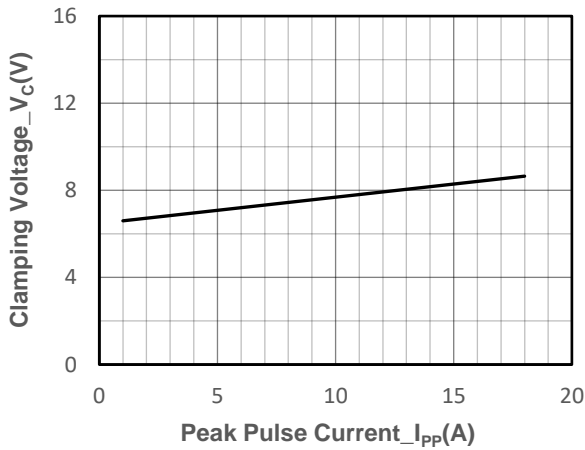

Clamping Voltage vs. Peak Pulse Current

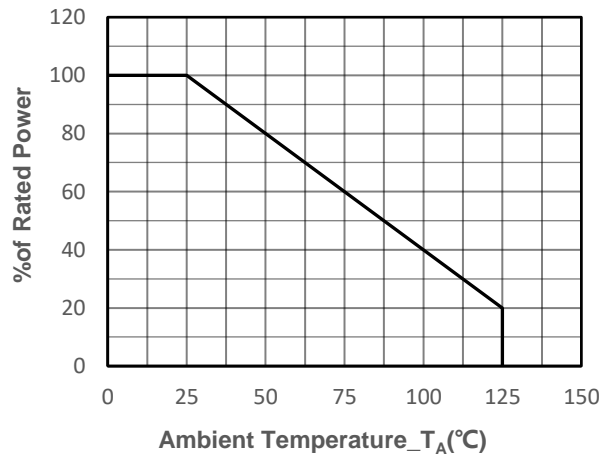

Power derating vs. Ambient temperature

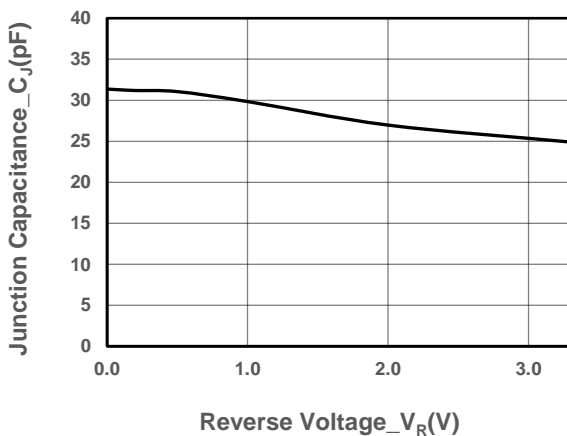

Junction Capacitance vs. Reverse Voltage

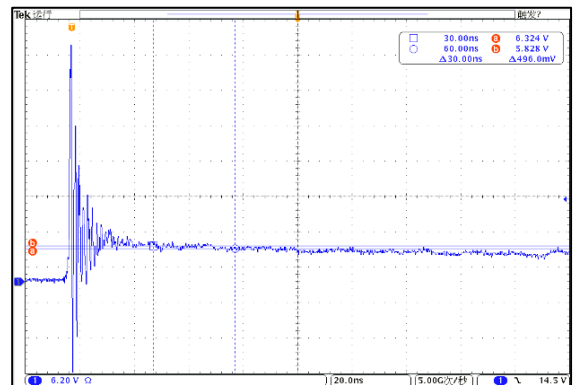

Note: Data is taken with a 10x attenuator  
**ESD Clamping Voltage**  
**8kV Contact per IEC61000-4-2**



## ● Package Information

### Ordering Information

Device	Package	Qty per Reel	Reel Size
SSCE3V372N1	DFN1006-2L	10000	7 Inch

### Mechanical Data

Case: DFN1006-2L

Case Material: Molded Plastic. UL Flammability

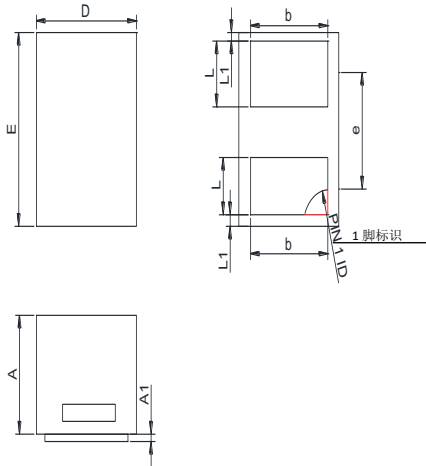

DIM	Millimeters	
	Min	Max
A	0.45	0.55
A1	0.00	0.05
D	0.55	0.65
E	0.95	1.05
b	0.45	0.60
e	0.65TYP	
L	0.2	0.3
L1	0.05REF	

### Recommended Pad outline (Unit: mm)

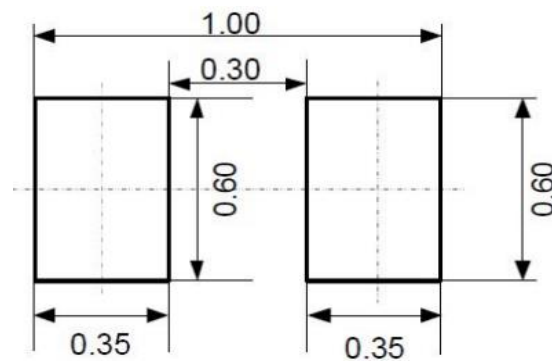



## DISCLAIMER

AFSEMI RESERVES THE RIGHT TO MAKE CHANGES WITHOUT FURTHER NOTICE TO ANY PRODUCTS HEREIN TO IMPROVE RELIABILITY, FUNCTION OR DESIGN. AFSEMI DOES NOT ASSUME ANY LIABILITY ARISING OUT OF THE APPLICATION OR USE OF ANY PRODUCT OR CIRCUIT DESCRIBED HEREIN; NEITHER DOES IT CONVEY ANY LICIENCE UNDER ITS PATENT RIGHTS, NOR THE RIGHTS OF OTHERS.

THE GRAPHS PROVIDED IN THIS DOCUMENT ARE STATISTICAL SUMMARIES BASED ON A LIMITED NUMBER OF SAMPLES AND ARE PROVIDED FOR INFORMATIONAL PURPOSE ONLY. THE PERFORMANCE CHARACTERISTICS LISTED IN THEM ARE NOT TESTED OR GUARANTEED. IN SOME GRAPHS, THE DATA PRESENTED MAY BE OUTSIDE THE SPECIFIED OPERATING RANGE (E.G. OUTSIDE SPECIFIED POWER SUPPLY RANGE) AND THEREFORE OUTSIDE THE WARRANTED RANGE.